

Thermal Economics Ltd

Thermal House
8 Cardiff Road
Luton
Bedfordshire LU1 1PP

Tel: 01582 450 814

e-mail: info@thermal-economics.co.uk

website: www.thermal-economics.co.uk



Agrément Certificate

93/2861

Product Sheet 3 Issue 3

ALREFLEX RANGE OF CAVITY WALL INSULATION AND CAVITY RAIN BARRIERS

ALREFLEX ULTRATHERM

This Agrément Certificate Product Sheet⁽¹⁾ relates to Alreflex Ultratherm, comprising a single-layer polyethylene bubble sheet faced on one side with aluminium foil, attached to a rigid polyisocyanurate (PIR) foam board with a composite foil-facing on both sides, for use as partial fill insulation (with a minimum 50 mm residual cavity) in new external masonry cavity walls, in domestic and non-domestic buildings, with height restrictions.

(1) Hereinafter referred to as 'Certificate'.

The assessment includes

Product factors:

- compliance with Building Regulations
- compliance with additional regulatory or non-regulatory information where applicable
- evaluation against technical specifications
- assessment criteria and technical investigations
- uses and design considerations

Process factors:

- compliance with Scheme requirements
- installation, delivery, handling and storage
- production and quality controls
- maintenance and repair

Ongoing contractual Scheme elements†:

- regular assessment of production
- formal 3-yearly review

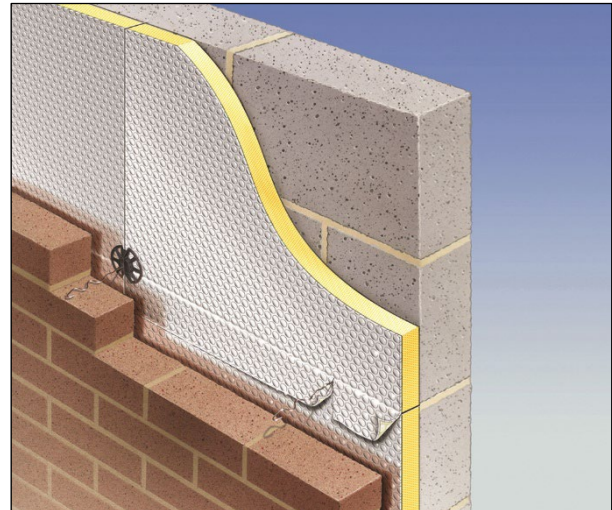

KEY FACTORS ASSESSED

- Section 1. Mechanical resistance and stability
- Section 2. Safety in case of fire
- Section 3. Hygiene, health and the environment
- Section 4. Safety and accessibility in use
- Section 5. Protection against noise
- Section 6. Energy economy and heat retention
- Section 7. Sustainable use of natural resources
- Section 8. Durability

The BBA has awarded this Certificate to the company named above for the product described herein. This product has been assessed by the BBA as being fit for its intended use provided it is installed, used and maintained as set out in this Certificate.

On behalf of the British Board of Agrément

Date of Third issue: 7 May 2025
Originally certified on 28 January 2010

Hardy Giesler
Chief Executive Officer

This BBA Agrément Certificate is issued under the BBA's Inspection Body accreditation to ISO/IEC 17020. Sections marked with † are not issued under accreditation.

The BBA is a UKAS accredited Inspection Body (No. 4345), Certification Body (No. 0113) and Testing Laboratory (No. 0357).

Readers MUST check that this is the latest issue of this Agrément Certificate by either referring to the BBA website or contacting the BBA directly.

The Certificate should be read in full as it may be misleading to read clauses in isolation.

Any photographs are for illustrative purposes only, do not constitute advice and should not be relied upon.

British Board of Agrément

1st Floor, Building 3, Hatters Lane
Croxley Park, Watford
Herts WD18 8YG

©2025

tel: 01923 665300
clientservices@bbacerts.co.uk
www.bbacerts.co.uk

SUMMARY OF ASSESSMENT AND COMPLIANCE

This section provides a summary of the assessment conclusions; readers should refer to the later sections of this Certificate for information about the assessments carried out.

Compliance with Regulations

Having assessed the key factors, the opinion of the BBA is that Alreflex Ultratherm, if installed, used and maintained in accordance with this Certificate, can satisfy or contribute to satisfying the relevant requirements of the following Building Regulations:



The Building Regulations 2010 (England and Wales) (as amended)

Requirement: B3(4)	Internal fire spread (structure)
Comment:	The product can contribute to satisfying this Requirement. See section 2 of this Certificate.
Requirement: B4(1)	External fire spread
Comment:	The product is restricted by this Requirement in some cases. See section 2 of this Certificate.
Requirement: C2(a)	Resistance to moisture
Comment:	The product can contribute to satisfying this Requirement. See section 3 of this Certificate.
Requirement: C2(b)	Resistance to moisture
Comment:	The products can contribute to satisfying this Requirement. See section 9 of this Certificate.
Requirement: C2(c)	Resistance to moisture
Comment:	The product can contribute to satisfying this Requirement. See section 3 of this Certificate.
Requirement: L1(a)(i)	Conservation of fuel and power
Comment:	The product can contribute to satisfying this Requirement. See section 6 of this Certificate.
Regulation: 7(1)	Materials and workmanship
Comment:	The product is acceptable. See sections 8 and 9 of this Certificate.
Regulation: 7(2)	Materials and workmanship
Comment:	The product is restricted by this Regulation. See section 2 of this Certificate.
Regulation: 25B	Nearly zero-energy requirements for new buildings
Regulation: 26	CO₂ emission rates for new buildings
Regulation: 26A	Fabric energy efficiency rates for new dwellings (applicable to England only)
Regulation: 26A	Primary energy rates for new buildings (applicable to Wales only)
Regulation: 26B	Fabric performance values for new dwellings (applicable to Wales only)
Regulation: 26C	Target primary energy rates for new buildings (applicable to England only)
Regulation: 26C	Energy efficiency rating (applicable to Wales only)
Comment:	The product can contribute to satisfying these Regulations. See section 6 of this Certificate.



The Building (Scotland) Regulations 2004 (as amended)

Regulation:	8(1)	Fitness and durability of materials and workmanship
Comment:		The product is acceptable. See sections 8 and 9 of this Certificate.
Regulation:	9	Building standards – construction
Standard:	2.4	Cavities
Comment:		The product can contribute to satisfying this Standard, with reference to clauses 2.4.2 ⁽¹⁾⁽²⁾ and 2.4.4 ⁽¹⁾⁽²⁾ . See section 2 of this Certificate.
Standard:	2.6	Spread to neighbouring buildings
Comment:		The product is restricted by this Standard in some cases, with reference to clauses 2.6.5 ⁽¹⁾ and 2.6.6 ⁽²⁾ . See section 2 of this Certificate.
Standard:	3.4	Moisture from the ground
Comment:		The product can contribute to satisfying this Standard, with reference to clauses 3.4.1 ⁽¹⁾⁽²⁾ and 3.4.5 ⁽¹⁾⁽²⁾ . See section 3 of this Certificate.
Standard:	3.10	Precipitation
Comment:		The products can contribute to satisfying this Standard, with reference to clauses 3.10.1 ⁽¹⁾⁽²⁾ and 3.10.3 ⁽¹⁾⁽²⁾ . See section 9 of this Certificate.
Standard:	3.15	Condensation
Comment:		The product can contribute to satisfying this Standard, with reference to clauses 3.15.1 ⁽¹⁾⁽²⁾ , 3.15.4 ⁽¹⁾⁽²⁾ and 3.15.5 ⁽¹⁾⁽²⁾ . See section 3 of this Certificate.
Standard:	6.1(b)(c)	Energy demand
Comment:		The product can contribute to satisfying this Standard, with reference to clauses 6.1.1 ⁽¹⁾ and 6.1.2 ⁽²⁾ . See section 6 of this Certificate.
Standard:	6.2	Building insulation envelope
Comment:		The product can contribute to satisfying this Standard with reference to clauses 6.2.1 ⁽¹⁾⁽²⁾ , 6.2.3 ⁽¹⁾ , 6.2.4 ⁽²⁾ , 6.2.8 ⁽¹⁾ , 6.2.9 ⁽²⁾ and 6.2.12 ⁽¹⁾ . See section 6 of this Certificate.
Standard:	7.1(a)(b)	Statement of sustainability
Comment:		The product can contribute to satisfying the relevant requirements of Regulation 9, Standards 1 to 6, and therefore will contribute to a construction meeting at least a bronze level of sustainability as defined in this Standard. In addition, the product can contribute to a construction meeting a higher level of sustainability as defined in this Standard, with reference to clauses 7.1.4 ⁽¹⁾ , 7.1.6 ⁽¹⁾⁽²⁾ , 7.1.7 ⁽¹⁾ , 7.1.9 ⁽²⁾ and 7.1.10 ⁽²⁾ . See section 6 of this Certificate.
Regulation:	12	Building standards – conversion
Comment:		Comments made in relation to this product under Regulation 9, Standards 1 to 6, also apply to this Regulation, with reference to clause 0.12.1 ⁽¹⁾⁽²⁾ and Schedule 6 ⁽¹⁾⁽²⁾ .

(1) Technical Handbook (Domestic).
(2) Technical Handbook (Non-Domestic).



The Building Regulations (Northern Ireland) 2012 (as amended)

Regulation:	23(1)(a)(i)(iii)	Fitness of materials and workmanship
Comment:	(b)(i)(ii)	The product is acceptable. See sections 8 and 9 of this Certificate.
Regulation:	23(2)	Fitness of materials and workmanship
Comment:		The product is restricted by this Regulation. See section 2 of this Certificate.
Regulation:	28(a)	Resistance to moisture and weather
Comment:		The product can contribute to satisfying this Regulation. See section 3 of this Certificate.
Regulation:	28(b)	Resistance to moisture and weather
Comment:		The product can contribute to satisfying this Regulation. See section 9 of this Certificate.
Regulation:	29	Condensation
Comment:		The product can contribute to satisfying this Regulation. See section 3 of this Certificate.
Regulation:	35(4)	Internal fire spread – structure
Comment:		The product can contribute to satisfying this Regulation. See section 2 of this Certificate.
Regulation:	36(a)	External fire spread
Comment:		The product is restricted by this Regulation in some cases. See section 2 of this Certificate.
Regulation:	39(a)(i)	Conservation measures
Regulation:	40(2)	Target carbon dioxide emission rate
Regulation:	43B	Nearly zero-energy requirements for new buildings
Comment:		The product can contribute to satisfying these Regulations. See section 6 of this Certificate.

Additional Information

NHBC Standards 2025

In the opinion of the BBA, Alreflex Ultratherm, if installed, used and maintained in accordance with this Certificate, can satisfy or contribute to satisfying the relevant requirements in relation to *NHBC Standards*, Chapter 6.1 *External masonry walls*.

Fulfilment of Requirements

The BBA has judged Alreflex Ultratherm to be satisfactory for use as described in this Certificate. The product has been assessed as partial fill insulation in new external masonry cavity walls with a minimum residual cavity of 50 mm, in domestic and non-domestic buildings, with height restrictions.

ASSESSMENT

Product description and intended use

The Certificate holder provided the following description for the product under assessment. Alreflex Ultratherm comprises a single-layer polyethylene bubble sheet faced on one side with aluminium foil, attached to a rigid PIR foam board with a composite foil-facing on both sides. The product is manufactured with an overlap of the foil-faced bubble wrap.

The product has the nominal characteristics given in Table 1.

Table 1 Nominal characteristics

Characteristic (unit)	Value
Length (mm)	1200
Width (mm)	450
Thickness of the bubble film (mm)	3
Thickness of the rigid board (mm) ⁽¹⁾	25 to 140 mm, in 5 mm increments
Edge detail	Square with bubble wrap/foil overlap

(1) A thickness of 150 mm is available for cavities with a width of 200 mm.

Applications

The product is intended for use as partial fill cavity wall insulation in external cavity walls with masonry inner and outer leaves (where masonry includes clay and calcium silicate bricks, concrete blocks, and natural and reconstituted stone blocks).

Ancillary Items

The Certificate holder recommends the following ancillary items for use with the product, but these materials have not been assessed by the BBA and are outside the scope of this Certificate:

- cavity wall ties with insulation-retaining clips/fixings to BS EN 845-1 : 2013
- foil tape.

Product assessment – key factors

The product was assessed for the following key factors, and the outcome of the assessments is shown below. Conclusions relating to the Building Regulations apply to the whole of the UK unless otherwise stated.

1 Mechanical resistance and stability

Not applicable.

2 Safety in case of fire

Data were assessed for the following characteristics.

2.1 Reaction to fire

2.1.1 The Certificate holder has not declared a reaction to fire classification to BS EN 13501-1 : 2018 for the product.

2.1.2 On the basis of data assessed, the product will be restricted in use under the documents supporting the national Building Regulations in some cases.

2.1.3 In England, Wales and Northern Ireland, the product must not be used on buildings with a storey 18 m or more above ground level which contain one or more dwellings, an institution, a room for residential purposes (excluding any room in a hostel, hotel or boarding house in Wales and Northern Ireland only), student accommodation, care homes, sheltered housing, hospitals or dormitories in boarding schools and, additionally in Northern Ireland, nursing homes and places of lawful detention.

2.1.4 In England, Wales and Northern Ireland, the product is unrestricted in terms of proximity to a relevant boundary and, for constructions comprising two leaves of brick or concrete each at least 75 mm thick and with cavities closed around openings and at the top of the wall (with cavity barriers in Northern Ireland), is also unrestricted in terms of height, except for those constructions described in section 2.1.3.

2.1.5 In England, Wales and Northern Ireland, for constructions other than those described in sections 2.1.3 or 2.1.4, the product must not be used on buildings with a floor more than 18 m above ground level, or in England only, it must not be used on residential buildings with a storey 11 m or more in height.

2.1.6 In Scotland, the product may be used without restriction on height or proximity to a relevant boundary, provided it is installed in a cavity that is between two leaves of masonry at least 75 mm thick, and which has a cavity barrier around all openings in the wall and at the top of the wall head. For other constructions, the product must not be used on buildings with a storey at a height of 11 m or more above ground level or within 1 m of a relevant boundary.

2.1.7 Designers must refer to the relevant national Building Regulations and guidance for detailed conditions of use, particularly in respect of requirements for substrate fire performance, cavity closers and barriers, fire stopping of service penetrations and combustibility limitations for other materials and components used in the overall wall construction.

3 Hygiene, health and the environment

Data were assessed for the following characteristics.

3.1 Effectiveness against rising damp

3.1.1 The product was tested for short-term water absorption by partial immersion and the result is given in Table 2.

Table 2 Short-term water absorption by partial immersion

Product assessed	Assessment method	Requirement	Result
Alreflex Ultratherm	BS EN 1609 : 2013	$\leq 1.25 \text{ kg} \cdot \text{m}^{-2}$	Pass

3.1.2 The product may be used in situations where it bridges the damp-proof course (DPC) in walls; dampness from the ground will not pass through to the inner leaf provided the wall is detailed in accordance with the requirements and provisions of the national Building Regulations.

3.2 Water vapour permeability

The water vapour resistance and resistivity of the product are given in Table 3.

Table 3 Water vapour resistance/resistivity

Material	Assessment method	Requirement	Result
PIR insulation	BS EN ISO 10456 : 2007	Value achieved	$300 \text{ MN} \cdot \text{s} \cdot \text{g}^{-1} \cdot \text{m}^{-1}$
PIR composite foil facer	BS 5250 : 2021		$1000 \text{ MN} \cdot \text{s} \cdot \text{g}^{-1}$
Bubble film	BS EN ISO 10456 : 2007		$150 \text{ MN} \cdot \text{s} \cdot \text{g}^{-1}$

4 Safety and accessibility in use

Not applicable.

5 Protection against noise

Not applicable.

6 Energy economy and heat retention

Data were assessed for the following characteristics.

6.1 Thermal conductivity

The product was tested for thermal conductivity and thermal resistance, and the results are given in Table 4.

Table 4 Thermal conductivity and thermal resistance

Product assessed	Assessment method	Requirement	Result
PIR insulation	Thermal conductivity to BS EN 13165 : 2012	Declared value (λ_D)	0.022 W·m ⁻¹ ·K ⁻¹
Bubble film	Thermal resistance to BS EN 12667 : 2001	Declared value	0.10 m ² ·K·W ⁻¹

6.2 Thermal performance

The product was tested for emissivity and the result is given in Table 5.

Table 5 Outer surface emissivity

Product assessed	Assessment method	Requirement	Result
Bubble film	BS EN ISO 22097 : 2023	Declared value	0.05

6.3 Conservation of fuel and power

6.3.1 The U value of a completed wall will depend on the insulation thickness, its structure and its internal finish. Example U values are given in Table 6.

Table 6 Example U values⁽¹⁾ – partial fill insulation (50 mm residual cavity)

U value (W·m ⁻² ·K ⁻¹)	PIR insulation thickness (mm)	
	13 mm dense plaster 100 mm dense block ⁽²⁾	Plasterboard on dabs 100 mm AAC block ⁽³⁾
0.13	140	125
0.15	120	100
0.17	100	85
0.18	95	80
0.21	80	65
0.26	60	45
0.28	55	40
0.30	50	30

(1) The U value calculations are based on the following:

- cavity wall ties – mild steel ($\lambda = 50 \text{ W}\cdot\text{m}^{-1}\cdot\text{K}^{-1}$), 2.5 per m², 3.30 mm² cross-section
- 102.5 mm brick ($\lambda = 0.77 \text{ W}\cdot\text{m}^{-1}\cdot\text{K}^{-1}$)
- 50 mm low e cavity ($R = 0.665 \text{ m}^2\cdot\text{K}\cdot\text{W}^{-1}$).

(2) 100 mm dense block ($\lambda = 1.13 \text{ W}\cdot\text{m}^{-1}\cdot\text{K}^{-1}$) bridged by mortar (6.7%, $\lambda = 0.88 \text{ W}\cdot\text{m}^{-1}\cdot\text{K}^{-1}$) and 13 mm dense plaster ($\lambda = 0.57 \text{ W}\cdot\text{m}^{-1}\cdot\text{K}^{-1}$).

(3) 100 mm AAC block ($\lambda = 0.12 \text{ W}\cdot\text{m}^{-1}\cdot\text{K}^{-1}$) bridged by mortar (6.7%, $\lambda = 0.88 \text{ W}\cdot\text{m}^{-1}\cdot\text{K}^{-1}$) and 12.5 mm plasterboard ($\lambda = 0.25 \text{ W}\cdot\text{m}^{-1}\cdot\text{K}^{-1}$), affixed by plaster dabs (20%, $\lambda = 0.43 \text{ W}\cdot\text{m}^{-1}\cdot\text{K}^{-1}$) bridging a 15 mm air cavity ($R = 0.17 \text{ m}^2\cdot\text{K}\cdot\text{W}^{-1}$).

6.3.2 The product can contribute towards a construction satisfying the national Building Regulations in respect of energy economy and heat retention.

7 Sustainable use of natural resources

Not applicable.

8 Durability

8.1 The potential mechanisms for degradation and the known performance characteristics of the materials in the product were assessed.

8.2 Specific test data were assessed as given in Table 7.

Product assessed	Assessment method	Requirement	Result
Alreflex Ultratherm	Dimensional stability to BS EN 1604 : 2013 (70°C and 90-100% RH for 48 hours)	Length and width \leq 1% change Thickness \leq 4% change	Pass

8.3 Service life

Under normal service conditions, the product will have a life equivalent to the building in which it is incorporated, provided it is designed, installed and maintained in accordance with this Certificate and the Certificate holder's instructions.

PROCESS ASSESSMENT

Information provided by the Certificate holder was assessed for the following factors:

9 Design, installation, workmanship and maintenance

9.1 Design

9.1.1 The design process was assessed by the BBA, and the following requirements apply in order to satisfy the performance assessed in this Certificate.

9.1.2 External masonry cavity walls must be designed and constructed in accordance with the relevant recommendations of:

- BS 5250 : 2021
- BS 8000-3 : 2020
- BS EN 845-1 : 2013
- BS EN 1996-1-1 : 2005 and its UK National Annex
- BS EN 1996-1-2 : 2005 and its UK National Annex
- BS EN 1996-2 : 2006 and its UK National Annex
- BS EN 1996-3 : 2006 and its UK National Annex.

9.1.3 As with other forms of cavity wall insulation, where buildings need to comply with the *NHBC Standards*, specifiers must observe the requirements of that document.

9.1.4 Cavity wall ties with insulation-retaining fixings and, if required, any additional ties to BS EN 845-1 : 2013, must be used for structural stability in accordance with BS EN 1996-1-1 : 2005, BS EN 1996-2 : 2006 and BS EN 1996-3 : 2006, and their UK National Annexes.

9.1.5 Care must be taken in the overall design and construction of walls incorporating the product to ensure the provision of appropriate:

- cavity trays and DPCs
- cavity barriers
- resistance to the ingress of precipitation, moisture and dangerous gases from the ground
- resistance to sound transmission when flanking separating walls and floors.

9.1.6 Provided that external masonry cavity walls are designed and constructed to incorporate the precautions in this Certificate to prevent moisture penetration, the product will resist the transfer of precipitation to the inner leaf.

9.1.7 Window and door opening reveals must be constructed incorporating a cavity barrier/closer/DPC, as required.

9.1.8 The detailed provisions given in the documents supporting the national Building Regulations for when the product is installed in close proximity to certain flue pipes and/or heat-producing appliances must be followed.

9.1.9 Calculations of the thermal transmittance (U value) of a wall must be carried out in accordance with BS EN ISO 6946 : 2017 and BRE Report BR 443 : 2019.

9.1.10 Care must be taken in the overall design and construction of junctions with other elements and openings to minimise thermal bridges and air infiltration. Detailed guidance can be found in the documents supporting the national Building Regulations.

Interstitial condensation

9.1.11 Walls will adequately limit the risk of interstitial condensation when they are designed and constructed in accordance with BS 5250 : 2021.

9.1.12 If the product is to be used in the external wall of rooms expected to have high humidity, care must be taken to provide adequate permanent ventilation to avoid possible problems from the formation of interstitial condensation.

Surface condensation

9.1.13 In England and Wales, walls will adequately limit the risk of surface condensation when the thermal transmittance (U value) does not exceed $0.7 \text{ W}\cdot\text{m}^{-2}\cdot\text{K}^{-1}$ at any point, and the junctions with other elements are designed in accordance with the guidance referred to in section 9.1.10 of this Certificate.

9.1.14 For buildings in Scotland, wall constructions will be acceptable when the thermal transmittance (U value) does not exceed $1.2 \text{ W}\cdot\text{m}^{-2}\cdot\text{K}^{-1}$ at any point, and the junctions with other elements are designed in accordance with the guidance referred to in BS 5250 : 2021. Further guidance may be obtained from BRE Report BR 262 : 2002 and section 9.1.10 of this Certificate.

Buildings up to and including 25 metres high (see also section 2 of this Certificate)

9.1.15 The residual cavity width to be maintained during construction is 50 mm. This may reduce to 25 mm in isolated areas due to individual construction features [a minimum of 50 mm residual cavity width is required by the NHBC⁽¹⁾]. This may be achieved by designing a cavity width which considers the dimensional tolerances of the components which make up the wall (by reference to the British Standards relating to the bricks, blocks and boards, or by using the data from the respective manufacturers). Allowances may need to be made for the quality of building operatives and the degree of site supervision or control available. The limitations in respect of exposure of the proposed building as set out in Table 8 of this Certificate must also be observed.

(1) The NHBC requirement for a residual cavity width is increased to 75 mm in areas of very severe exposure where the outer leaf is fairfaced masonry.

Table 8 Maximum allowable exposure index $E^{(1)}$

Construction	Maximum allowable exposure index $E^{(1)}$
All external masonry walls protected by: rendering (to BS EN 13914-1 : 2016), tile hanging, slate hanging, or timber, plastic or metal weatherboarding or cladding	No restriction
One or more external masonry walls constructed from facing clay brickwork or natural stone, the porosity of which exceeds 20% by volume. Mortar joints must be flush pointed or weatherstruck	100
One or more external masonry walls constructed from calcium silicate bricks, concrete blocks, reconstituted stone, or natural stone, the porosity of which is less than 20% by volume, or any material with raked mortar joints	88

(1) To BS 5618 : 1985.

9.1.16 From ground level, the maximum height of continuous cavity walls must not exceed 12 metres; above 12 metres, the maximum height of continuous cavity walls must not exceed 7 metres. In both cases, breaks must be in the form of continuous horizontal cavity trays and weepholes discharging to the outside.

9.1.17 An external render coat or other suitable finish must be applied in locations where such application would be normal practice; care must be taken to ensure that the residual cavity is not bridged by mortar.

Buildings over 25 metres in height (see also section 2 of this Certificate)

9.1.18 The width of the residual clear cavity to be achieved must be in excess of 50 mm, and the following additional requirements apply in addition to those stated in 9.1.15 to 9.1.17:

- the specifier must take extra care when detailing to ensure that the introduction of the insulation does not affect the weather resistance of the wall. Above average site supervision is recommended during installation of the product
- where, for structural reasons, the cavity width is reduced, eg by the intrusion of ring beams, a minimum residual cavity width of 25 mm must be maintained and extra care must be taken with fixings and weatherproofing, eg the inclusion of cavity trays with weepholes.

9.2 Installation

9.2.1 Installation instructions provided by the Certificate holder were assessed and judged to be appropriate and adequate.

9.2.2 Installation must be carried out in accordance with this Certificate and the Certificate holder's instructions. A summary of instructions and guidance is provided in Annex A of this Certificate.

9.2.3 The inner leaf must be constructed ahead of the outer leaf, as the boards are fastened to the cavity face of the inner leaf. It is essential that the spacing of wall ties/clips allows one long edge of each board to be secured at a minimum of two points.

9.2.4 Vertical joints in the boards must be staggered and all joints tightly butted. Where protrusions occur in the cavity, the boards must be carefully cut to fit.

9.2.5 If installation of the boards is terminated below the highest level of the wall, the top edge of the insulation must be protected by a cavity tray and alternate perpend joints raked out to provide adequate drainage of water from the tray.

9.2.6 In all situations, it is particularly important to ensure during installation that:

- installation is carried out to the highest level on each wall, or the top edge of the insulation is protected by a cavity tray
- cavity trays are used with appropriate stop ends and weepholes at lintel level
- cavity battens and/or boards are used during construction to prevent bridging by mortar droppings

- wall ties are installed correctly and are thoroughly clean
- excess mortar is cleaned from the cavity face of the leading leaf and any debris removed from the cavity
- mortar droppings are cleaned from the exposed edges of installed boards
- insulation boards are properly installed and butt-jointed
- the DPC at ground level does not project into the cavity, as it can form a trap for mortar bridging
- raked or recessed mortar joints are avoided in very severe exposure areas.

9.3 Workmanship

Practicability of installation was assessed by the BBA, on the basis of Certificate holder's information. To achieve the performance described in this Certificate, installation of the product must be carried out by a competent general builder, or a contractor, experienced with this type of product.

9.4 Maintenance and repair

As the product is confined within the wall cavity and has suitable durability, maintenance is not required.

10 **Manufacture**

10.1 The production processes for the product have been assessed, and provide assurance that the quality controls are satisfactory according to the following factors:

10.1.1 The manufacturer has provided documented information on the materials, processes, testing and control factors.

10.1.2 The quality control operated over batches of incoming materials has been assessed and deemed appropriate and adequate.

10.1.3 The quality control procedures and product testing to be undertaken have been assessed and deemed appropriate and adequate.

10.1.4 The process for management of non-conformities has been assessed and deemed appropriate and adequate.

10.1.5 An audit of each production location was undertaken, and it was confirmed that the production process was in accordance with the documented process, and that equipment has been properly tested and calibrated.

† 10.2 The BBA has undertaken to review the above measures on a regular basis through a surveillance process, to verify that the specifications and quality control operated by the manufacturer are being maintained.

11 **Delivery and site handling**

11.1 The Certificate holder stated that the product is delivered to site wrapped in polythene with the production code printed on each board. Each pallet carries a label bearing the production date, board size and thickness.

11.2 Delivery and site handling must be performed in accordance with the Certificate holder's instructions and this Certificate, including:

11.2.1 The product must be protected from prolonged exposure to direct sunlight and UV and must be stored either under cover or protected with light-coloured, opaque polythene sheets. Where possible, packs should be stored inside. If stored outside, the product must be raised above ground level out of contact with ground moisture and must be protected from rain.

11.2.2 The product must not be exposed to naked flame or other ignition sources. Care must be taken to avoid contact with solvents and with materials containing volatile organic compounds. Damaged product must be discarded.

Supporting information in this Annex is relevant to the product but has not formed part of the material assessed for the Certificate.

Construction (Design and Management) Regulations 2015

Construction (Design and Management) Regulations (Northern Ireland) 2016

Information in this Certificate may assist the client, designer (including Principal Designer) and contractor (including Principal Contractor) to address their obligations under these Regulations.

Management Systems Certification for production

The management system of the manufacturer has been assessed and registered as meeting the requirements of BS EN ISO 9001 : 2015 and BS EN ISO 14001 : 2015 by Centre for Assessment (Certificates 23/1568 and 23/1570 respectively).

Additional information on installation

A.1 It is recommended that the inner leaf of the wall be constructed ahead of the outer leaf, as the product is fastened to the cavity face of the inner leaf. It is essential that the spacing of the wall ties/clips allows the long edge of each board to be secured at a minimum of two points.

A.2 A section of the inner leaf is built with the first row of wall ties, at approximately 600 mm horizontal spacing, where the insulation is to begin. It is recommended that the wall ties are not placed directly on the DPC. The first run of the product may commence below the DPC level to provide some edge insulation for the floor (see Figure 1).

Figure 1 Typical installation detail

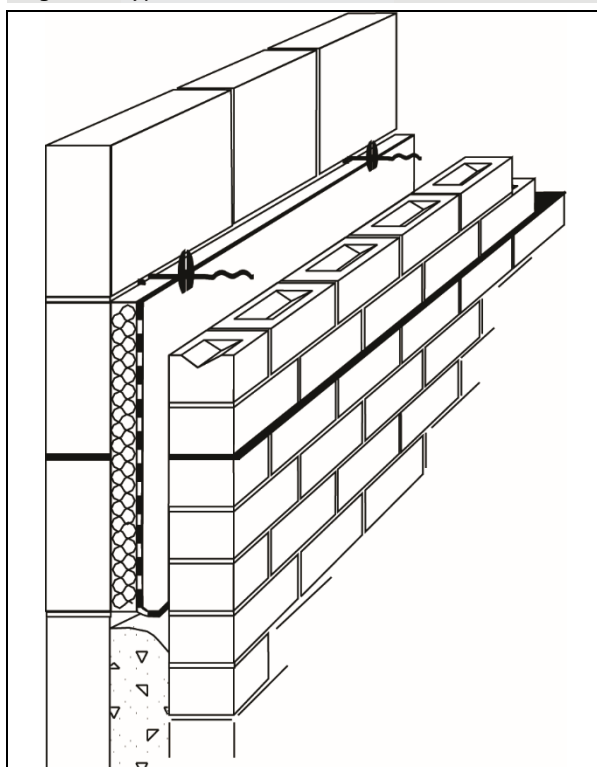

A.3 The leading leaf is built up to the required height, with wall ties placed at a vertical height of 450 mm, ensuring that the drip of the tie is located halfway across the residual cavity width. Excess mortar must be cleaned from the cavity face of the leading leaf, and the product is placed on the wall ties, behind the retaining clips, to form a closely butt-jointed run.

A.4 The second row of wall ties is fitted to retain the tops of the product. It is essential that all wall ties slope downwards towards the outer leaf (see Figure 2) and at centres not exceeding 900 mm to ensure that each board is secured at a minimum of three points. Additional ties may be required to satisfy the structural requirements of BS EN 845-1 : 2013, BS EN 1996-1-1 : 2005, BS EN 1996-2 : 2006 and BS EN 1996-3 : 2006 to ensure adequate retention of boards or cut pieces.

Figure 2 Installation of wall ties

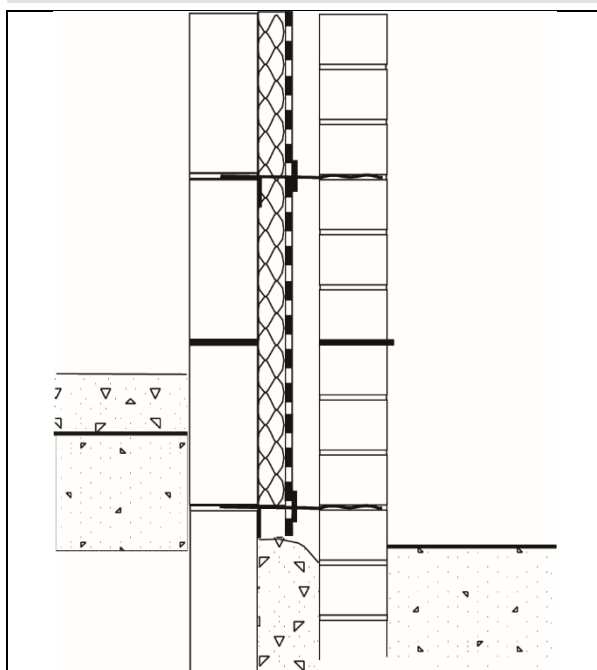

A.5 The other leaf is then built up to the level of the top of the product.

A.6 The product should be butted with vertical joints staggered. Insulation boards and wall ties should be staggered as construction proceeds and carried up to the highest level of wall, except where protected by a cavity tray.

Mortar droppings

A.7 After each section of the leading leaf is built, excess mortar must be removed from the cavity face and mortar droppings cleaned from exposed edges of the installed product before installation of the next run. Use of a cavity board or a cavity batten will protect the installed product and help to keep the cavity clean as the following leaf is built (see Figures 3 and 4).

Figure 3 Use of a cavity board

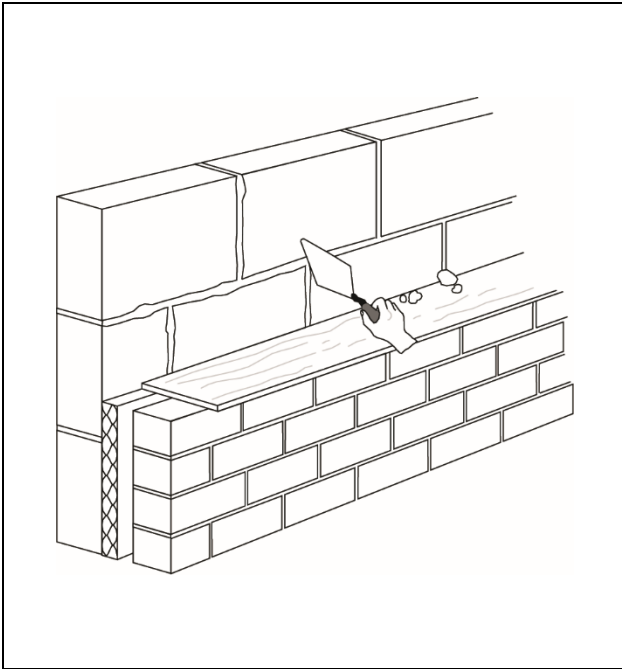
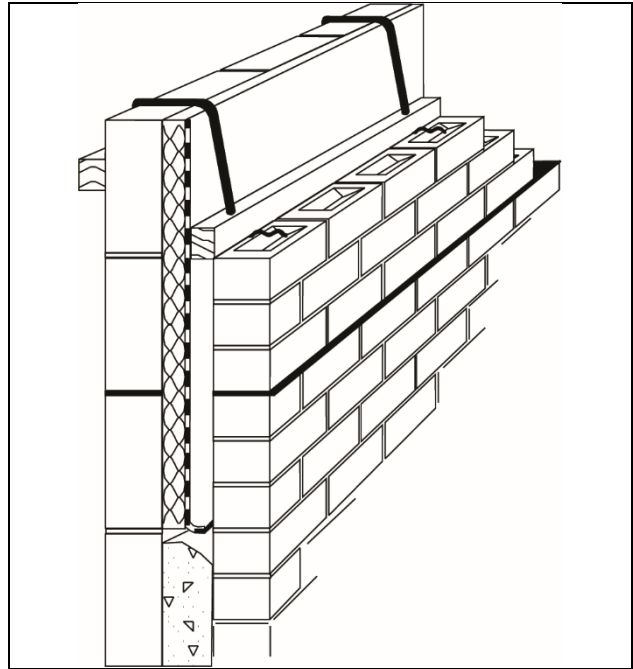

Figure 4 Use of a cavity batten



Wall openings

A.8 Where openings such as doors and windows are in close proximity, it is recommended that a continuous lintel or cavity tray is used. Individual lintels or cavity trays should have stop ends and be adequately drained.

Cut pieces

A.9 The product can be cut, using a sharp knife or fine-toothed saw, to fit around windows, doors or air bricks. It is essential that cut pieces completely fill the spaces for which they are intended and are adequately secured; gaps should not be left in the insulation.

Bibliography

- BRE Report BR 262 : 2002 *Thermal insulation: avoiding risks*
- BRE Report BR 443 : 2019 *Conventions for U-value calculations*
- BS 5250 : 2021 *Management of moisture in buildings — Code of practice*
- BS 5618 : 1985 *Code of practice for thermal insulation of cavity walls (with masonry or concrete inner and outer leaves) by filling with urea-formaldehyde (UF) foam systems*
- BS 8000-3 : 2020 *Workmanship on construction sites — Masonry — Code of practice*
- BS EN 845-1 : 2013 + A1 : 2016 *Specification for ancillary components for masonry — Wall ties, tension straps, hangers and brackets*
- BS EN 1604 : 2013 *Thermal insulating products for building applications — Determination of dimensional stability under specified temperature and humidity conditions*
- BS EN 1609 : 2013 *Thermal insulating products for building applications — Determination of short term water absorption by partial immersion*
- BS EN 1996-1-1 : 2005 *Eurocode 6 : Design of masonry structures — General rules for reinforced and unreinforced masonry structures*
- NA to BS EN 1996-1-1 : 2005 *UK National Annex to Eurocode 6 : Design of masonry structures — General rules for reinforced and unreinforced masonry structures*
- BS EN 1996-1-2 : 2005 + A1 : 2012 *Eurocode 6 : Design of masonry structures — General rules — Structural fire design*
- NA to BS EN 1996-1-2 : 2005 + A1 : 2012 *UK National Annex to Eurocode 6 : Design of masonry structures — General rules — Structural fire design*
- BS EN 1996-2 : 2006 *Eurocode 6 : Design of masonry structures — Design considerations, selection of materials and execution of masonry*
- NA to BS EN 1996-2 : 2006 *UK National Annex to Eurocode 6 — Design of masonry structures — Design considerations, selection of materials and execution of masonry*
- BS EN 1996-3 : 2006 *Eurocode 6 : Design of masonry structures — Simplified calculation methods for unreinforced masonry structures*
- NA + A1 : 2014 to BS EN 1996-3 : 2006 *UK National Annex to Eurocode 6 — Design of masonry structures — Simplified calculation methods for unreinforced masonry structures*
- BS EN 12667 : 2001 *Thermal performance of building materials and products — Determination of thermal resistance by means of guarded hot plate and heat flow meter methods — Products of high and medium thermal resistance*
- BS EN 13165 : 2012 + A2 : 2016 *Thermal insulation products for buildings — Factory made rigid polyurethane foam (PU) products — Specification*
- BS EN 13501-1 : 2018 *Fire classification of construction products and building elements — Classification using data from reaction to fire tests*
- BS EN 13914-1 : 2016 *Design, preparation and application of external rendering and internal plastering — External rendering*
- BS EN ISO 6946 : 2017 *Building components and building elements — Thermal resistance and thermal transmittance — Calculation method*
- BS EN ISO 9001 : 2015 *Quality management systems — Requirements*
- BS EN ISO 10456 : 2007 *Building materials and products — Hygrothermal properties — Tabulated design values and procedures for determining declared and design thermal values*
- BS EN ISO 14001 : 2015 *Environmental Management systems — Requirements with guidance for use*
- BS EN ISO 22097 : 2023 *Thermal insulation for buildings — Reflective insulation products — Determination of thermal performance*

Conditions

1 This Certificate:

- relates only to the product that is named and described on the front page
- is issued only to the company, firm, organisation or person named on the front page – no other company, firm, organisation or person may hold or claim that this Certificate has been issued to them
- is valid only within the UK
- has to be read, considered and used as a whole document – it may be misleading and will be incomplete to be selective
- is copyright of the BBA
- and any matter arising out of or in connection with it or its subject matter (including non-contractual disputes or claims) is governed by and construed in accordance with the law of England and Wales.
- the courts of England and Wales shall have exclusive jurisdiction to settle any matter arising out of or in connection with this Certificate or its subject matter (including non-contractual disputes or claims).

2 Publications, documents, specifications, legislation, regulations, standards and the like referenced in this Certificate are those that were current and/or deemed relevant by the BBA at the date of issue or reissue of this Certificate.

3 This Certificate will be displayed on the BBA website, and the Certificate Holder is entitled to use the Certificate and Certificate logo, provided that the product and its manufacture and/or fabrication, including all related and relevant parts and processes thereof:

- are maintained at or above the levels which have been assessed and found to be satisfactory by the BBA
- continue to be checked as and when deemed appropriate by the BBA under arrangements that it will determine
- are reviewed by the BBA as and when it considers appropriate.

4 The BBA has used due skill, care and diligence in preparing this Certificate, but no warranty is provided.

5 In issuing this Certificate the BBA is not responsible and is excluded from any liability to any company, firm, organisation or person, for any matters arising directly or indirectly from:

- the presence or absence of any patent, intellectual property or similar rights subsisting in the product or any other product
- the right of the Certificate holder to manufacture, supply, install, maintain or market the product
- actual installations of the product, including their nature, design, methods, performance, workmanship and maintenance
- any works and constructions in which the product is installed, including their nature, design, methods, performance, workmanship and maintenance
- any loss or damage, including personal injury, howsoever caused by the product, including its manufacture, supply, installation, use, maintenance and removal
- any claims by the manufacturer relating to UKCA marking and CE marking.

6 Any information relating to the manufacture, supply, installation, use, maintenance and removal of this product which is contained or referred to in this Certificate is the minimum required to be met when the product is manufactured, supplied, installed, used, maintained and removed. It does not purport in any way to restate the requirements of the Health and Safety at Work etc. Act 1974, or of any other statutory, common law or other duty which may exist at the date of issue or reissue of this Certificate; nor is conformity with such information to be taken as satisfying the requirements of the 1974 Act or of any statutory, common law or other duty of care.