

## Thermal Economics Ltd

Thermal House  
8 Cardiff Road  
Luton  
Bedfordshire LU1 1PP

Tel: 01582 450814

e-mail: [info@thermal-economics.co.uk](mailto:info@thermal-economics.co.uk)

website: [www.thermal-economics.co.uk](http://www.thermal-economics.co.uk)



**Agrément Certificate**

**93/2861**

Product Sheet 2 Issue 3

### ALREFLEX RANGE OF CAVITY WALL INSULATION AND CAVITY RAIN BARRIERS

#### ALREFLEX 1L1 AND ALREFLEX 1L1 SUPER 'R' CLASS 0

This Agrément Certificate Product Sheet<sup>(1)</sup> relates to Alreflex 1L1 and Alreflex 1L1 Super 'R' Class 0, single-layer polyethylene bubble sheets faced on one side with a lacquered aluminium foil, for use as partial fill insulation (with a minimum 50 mm residual cavity) and a rain barrier in external cavity walls with masonry inner and outer leaves, in new domestic or non-domestic buildings, with height restrictions.

(1) Hereinafter referred to as 'Certificate'.

#### The assessment includes

##### Product factors:

- compliance with Building Regulations
- compliance with additional regulatory or non-regulatory information where applicable
- evaluation against technical specifications
- assessment criteria and technical investigations
- uses and design considerations

##### Process factors:

- compliance with Scheme requirements
- installation, delivery, handling and storage
- production and quality controls
- maintenance and repair

##### Ongoing contractual Scheme elements†:

- regular assessment of production
- formal 3-yearly review

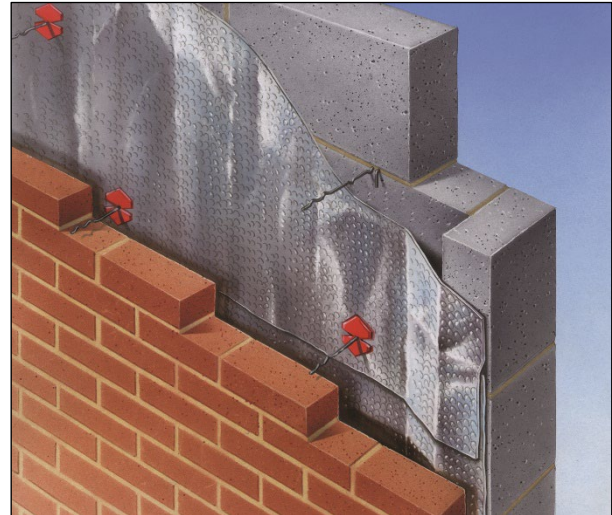

#### KEY FACTORS ASSESSED

- Section 1. Mechanical resistance and stability
- Section 2. Safety in case of fire
- Section 3. Hygiene, health and the environment
- Section 4. Safety and accessibility in use
- Section 5. Protection against noise
- Section 6. Energy economy and heat retention
- Section 7. Sustainable use of natural resources
- Section 8. Durability

The BBA has awarded this Certificate to the company named above for the products described herein. These products have been assessed by the BBA as being fit for their intended use provided they are installed, used and maintained as set out in this Certificate.

On behalf of the British Board of Agrément

Date of Third issue: 7 May 2025

Originally certified on 27 November 2001

Hardy Giesler  
Chief Executive Officer

*This BBA Agrément Certificate is issued under the BBA's Inspection Body accreditation to ISO/IEC 17020. Sections marked with † are not issued under accreditation.*

*The BBA is a UKAS accredited Inspection Body (No. 4345), Certification Body (No. 0113) and Testing Laboratory (No. 0357).*

*Readers MUST check that this is the latest issue of this Agrément Certificate by either referring to the BBA website or contacting the BBA directly.*

*The Certificate should be read in full as it may be misleading to read clauses in isolation.*

*Any photographs are for illustrative purposes only, do not constitute advice and should not be relied upon.*

#### British Board of Agrément

1<sup>st</sup> Floor Building 3  
Croxley Park, Watford  
Herts WD18 8YG

©2025

tel: 01923 665300  
[clientservices@bbacerts.co.uk](mailto:clientservices@bbacerts.co.uk)  
[www.bbacerts.co.uk](http://www.bbacerts.co.uk)

## SUMMARY OF ASSESSMENT AND COMPLIANCE

This section provides a summary of the assessment conclusions; readers should refer to the later sections of this Certificate for information about the assessments carried out.

### Compliance with Regulations

Having assessed the key factors, the opinion of the BBA is that Alreflex 1L1 and Alreflex 1L1 Super 'R' Class 0, if installed, used and maintained in accordance with this Certificate, can satisfy or contribute to satisfying the relevant requirements of the following Building Regulations:



#### The Building Regulations 2010 (England and Wales) (as amended)

<b>Requirement:</b> B3(4)	<b>Internal fire spread (structure)</b>
Comment:	The products can contribute to satisfying this Requirement. See section 2 of this Certificate.
<b>Requirement:</b> B4(1)	<b>External fire spread</b>
Comment:	The products are restricted by this Requirement in some cases. See section 2 of this Certificate.
<b>Requirement:</b> C2(a)	<b>Resistance to moisture</b>
Comment:	The products can contribute to satisfying this Requirement. See section 3 of this Certificate.
<b>Requirement:</b> C2(b)	<b>Resistance to moisture</b>
Comment:	The products can contribute to satisfying this Requirement. See section 9 of this Certificate.
<b>Requirement:</b> C2(c)	<b>Resistance to moisture</b>
Comment:	The products can contribute to satisfying this Requirement. See section 3 of this Certificate.
<b>Requirement:</b> L1(a)(i)	<b>Conservation of fuel and power</b>
Comment:	The products can contribute to satisfying this Requirement; however, compensating fabric measures may be required. See section 6 of this Certificate.
<b>Regulation:</b> 7(1)	<b>Materials and workmanship</b>
Comment:	The products are acceptable. See sections 8 and 9 of this Certificate.
<b>Regulation:</b> 7(2)	<b>Materials and workmanship (applicable to England only)</b>
Comment:	The products are restricted by this Regulation. See section 2 of this Certificate.
<b>Regulation:</b> 25B	<b>Nearly zero-energy requirements for new buildings</b>
<b>Regulation:</b> 26	<b>CO<sub>2</sub> emission rates for new buildings</b>
<b>Regulation:</b> 26A	<b>Fabric energy efficiency rates (applicable to England only)</b>
<b>Regulation:</b> 26A	<b>Primary energy efficiency rates for new buildings (applicable to Wales only)</b>
<b>Regulation:</b> 26B	<b>Fabric performance values for new dwellings (applicable to Wales only)</b>
<b>Regulation:</b> 26C	<b>Target primary energy rates for new buildings (applicable to England only)</b>
<b>Regulation:</b> 26C	<b>Energy efficiency rating (applicable to Wales only)</b>
Comment:	The products can contribute to satisfying these Regulations; however, compensating fabric/service measures may be required. See section 6 of this Certificate.



## The Building (Scotland) Regulations 2004 (as amended)

<b>Regulation:</b>	<b>8(1)</b>	<b>Fitness and durability of materials and workmanship</b>
Comment:		The products are acceptable. See sections 8 and 9 of this Certificate.
<b>Regulation:</b>	<b>8(3)</b>	<b>Fitness and durability of materials and workmanship</b>
Comment:		The products are restricted by this Regulation. See section 2 of this Certificate.
<b>Regulation:</b>	<b>9</b>	<b>Building standards – construction</b>
Standard:	2.4	Cavities
Comment:		The products can contribute to satisfying this Standard, with reference to clauses 2.4.2 <sup>(1)(2)</sup> and 2.4.4 <sup>(1)(2)</sup> . See section 2 of this Certificate.
Standard:	2.6	Spread to neighbouring buildings
Comment:		The products are restricted by this Standard in some cases, with reference to clauses 2.6.5 <sup>(1)</sup> and 2.6.6 <sup>(2)</sup> . See section 2 of this Certificate.
Standard:	3.4	Moisture from the ground
Comment:		The products can contribute to satisfying this Standard, with reference to clauses 3.4.1 <sup>(1)(2)</sup> and 3.4.5 <sup>(1)(2)</sup> . See section 3 of this Certificate.
Standard:	3.10	Precipitation
Comment:		The products can contribute to satisfying this Standard, with reference to clauses 3.10.1 <sup>(1)(2)</sup> and 3.10.3 <sup>(1)(2)</sup> . See section 9 of this Certificate.
Standard:	3.15	Condensation
Comment:		The products can contribute to satisfying this Standard, with reference to clauses 3.15.1 <sup>(1)(2)</sup> , 3.15.4 <sup>(1)(2)</sup> and 3.15.5 <sup>(1)(2)</sup> . See section 3 of this Certificate.
Standard:	6.1(b)(c)	Energy demand
Comment:		The products can contribute to satisfying this Standard with reference to clauses 6.1.1 <sup>(1)</sup> , and 6.1.2 <sup>(2)</sup> ; however, compensating fabric/service measures may be required. See section 6 of this Certificate.
Standard:	6.2	Building insulation envelope
Comment:		The products can contribute to satisfying this Standard with reference to clauses 6.2.1 <sup>(1)(2)</sup> , 6.2.3 <sup>(1)</sup> , 6.2.4 <sup>(2)</sup> , 6.2.8 <sup>(1)</sup> , 6.2.9 <sup>(2)</sup> and 6.2.12 <sup>(1)</sup> ; however, compensating fabric measures may be required. See section 6 of this Certificate.
Standard:	7.1(a)(b)	Statement of sustainability
Comment:		The products can contribute to satisfying the relevant requirements of Regulation 9, Standards 1 to 6, and therefore will contribute to a construction meeting at least a bronze level of sustainability as defined in this Standard. In addition, the products can contribute to a construction meeting a higher level of sustainability as defined in this Standard, with reference to clauses 7.1.4 <sup>(1)</sup> , 7.1.6 <sup>(1)(2)</sup> , 7.1.7 <sup>(1)</sup> , 7.1.9 <sup>(2)</sup> and 7.1.10 <sup>(2)</sup> . See section 6 of this Certificate.
<b>Regulation:</b>	<b>12</b>	<b>Building standards – conversion</b>
Comment:		Comments made in relation to the products under Regulation 9, Standards 1 to 6, also apply to this Regulation, with reference to clause 0.12.1 <sup>(1)(2)</sup> and Schedule 6 <sup>(1)(2)</sup> .

(1) Technical Handbook (Domestic).  
(2) Technical Handbook (Non-Domestic).



## The Building Regulations (Northern Ireland) 2012 (as amended)

<b>Regulation:</b>	<b>23(1)(a)(i)(iii)</b>	<b>Fitness of materials and workmanship</b>
<b>Comment:</b>	<b>(b)(i)(ii)</b>	The products are acceptable. See sections 8 and 9 of this Certificate.
<b>Regulation:</b>	<b>23(2)</b>	<b>Fitness of materials and workmanship</b>
<b>Comment:</b>		The products are restricted by this Regulation. See section 2 of this Certificate.
<b>Regulation:</b>	<b>28(a)</b>	<b>Resistance to moisture and weather</b>
<b>Comment:</b>		The products can contribute to satisfying this Regulation. See section 3 of this Certificate.
<b>Regulation:</b>	<b>28(b)</b>	<b>Resistance to moisture and weather</b>
<b>Comment:</b>		The products can contribute to satisfying this Regulation. See section 9 of this Certificate.
<b>Regulation:</b>	<b>29</b>	<b>Condensation</b>
<b>Comment:</b>		The products can contribute to satisfying this Regulation. See section 3 of this Certificate.
<b>Regulation:</b>	<b>35(4)</b>	<b>Internal fire spread – structure</b>
<b>Comment:</b>		The products can contribute to satisfying this Regulation. See section 2 of this Certificate.
<b>Regulation:</b>	<b>36(a)</b>	<b>External fire spread</b>
<b>Comment:</b>		The products are restricted by this Regulation in some cases. See section 2 of this Certificate.
<b>Regulation:</b>	<b>39(a)(i)</b>	<b>Conservation measures</b>
<b>Comment:</b>		The products can contribute to satisfying this Regulation; however, compensating fabric measures may be required. See section 6 of this Certificate.
<b>Regulation:</b>	<b>40(2)</b>	<b>Target carbon dioxide emission rate</b>
<b>Regulation:</b>	<b>43B</b>	<b>Nearly zero-energy requirements for new buildings</b>
<b>Comment:</b>		The products can contribute to satisfying these Regulations; however, compensating fabric/service measures may be required. See section 6 of this Certificate.

## Additional Information

### NHBC Standards 2025

In the opinion of the BBA, Alreflex 1L1 and Alreflex 1L1 Super 'R' Class 0, if installed, used and maintained in accordance with this Certificate, can satisfy or contribute to satisfying the relevant requirements in relation to *NHBC Standards*, Chapter 6.1 *External masonry walls*.

## Fulfilment of Requirements

The BBA has judged Alreflex 1L1 and Alreflex 1L1 Super 'R' Class 0 to be satisfactory for use as described in this Certificate. The products have been assessed for use as partial fill insulation (with a minimum 50 mm residual cavity) and a rain barrier in external cavity walls with masonry inner and outer leaves, in new domestic or non-domestic buildings, with height restrictions.

## ASSESSMENT

### Product description and intended use

The Certificate holder provided the following description for the products under assessment. Alreflex 1L1 and Alreflex 1L1 Super 'R' Class 0 consist of one layer of polyethylene bubble sheet manufactured with a lacquered aluminium foil-lining on one side.

The products have the nominal characteristics given in Table 1.

*Table 1 Nominal characteristics*

Product	Characteristic (unit)			
	Length (m)	Width (m)	Thickness (mm)	Closing tape colour
Alreflex 1L1	50	1.05	3.25	Blue
		1.2		
		1.5		
Arleflex 1L1 Super 'R' Class 0	50	1.05	3	Violet
		1.2		
		1.5		

#### Applications

The products are intended for use as partial fill cavity wall insulation in external cavity walls with masonry inner and outer leaves (where masonry includes clay and calcium silicate bricks, concrete blocks, and natural and reconstituted stone blocks).

#### Ancillary Items

The Certificate holder recommends the following ancillary items for use with the products, but these materials have not been assessed by the BBA and are outside the scope of this Certificate:

- cavity wall ties with insulation-retaining clips/fixings to BS EN 845-1 : 2013
- foil tape.

### Product assessment – key factors

The products were assessed for the following key factors, and the outcome of the assessments is shown below. Conclusions relating to the Building Regulations apply to the whole of the UK unless otherwise stated.

#### **1 Mechanical resistance and stability**

Not applicable.

#### **2 Safety in case of fire**

Data were assessed for the following characteristics.

##### 2.1 Reaction to fire

2.1.1 The Certificate holder has not declared a reaction to fire classification to BS EN 13501-1 : 2018 for the products.

2.1.2 On the basis of data assessed, the products will be restricted in use under the documents supporting the national Building Regulations in some cases.

2.1.3 In England, Wales and Northern Ireland, the products must not be used on buildings with a storey 18 m or more above ground level which contain one or more dwellings, an institution, a room for residential purposes (excluding any room in a hostel, hotel or boarding house in Wales and Northern Ireland only), student accommodation, care homes, sheltered housing, hospitals or dormitories in boarding schools and, additionally in Northern Ireland, nursing homes and places of lawful detention.

2.1.4 In England, Wales and Northern Ireland, the products are unrestricted in terms of proximity to a relevant boundary and, for constructions comprising two leaves of brick or concrete each at least 75 mm thick and with cavities closed around openings and at the top of the wall (with cavity barriers in Northern Ireland), are also unrestricted in terms of height, except for those constructions described in section 2.1.3.

2.1.5 In England, Wales and Northern Ireland, for constructions other than those described in sections 2.1.3 or 2.1.4, the products must not be used on buildings with a floor more than 18 m above ground level, or in England only, they must not be used on residential buildings with a storey 11 m or more in height.

2.1.6 In Scotland, the products may be used without restriction on height or proximity to a relevant boundary, provided they are installed in a cavity that is between two leaves of masonry at least 75 mm thick, and which has a cavity barrier around all openings in the wall and at the top of the wall head. For other constructions, the products must not be used on buildings with a storey at a height of 11 m or more above ground level or within 1 m of a relevant boundary.

2.1.7 Designers must refer to the relevant national Building Regulations and guidance for detailed conditions of use, particularly in respect of requirements for substrate fire performance, cavity closers and barriers, fire stopping of service penetrations and combustibility limitations for other materials and components used in the overall wall construction.

### 3 Hygiene, health and the environment

Data were assessed for the following characteristics.

#### 3.1 Effectiveness against rising damp

The products may be used in situations where they bridge the damp-proof course (DPC) in walls; dampness from the ground will not pass through to the inner leaf provided the wall is detailed in accordance with the requirements and provisions of the national Building Regulations.

#### 3.2 Water vapour permeability

3.2.1 The water vapour resistance of the products is given in Table 2.

*Table 2 Water vapour resistance*

Product assessed	Assessment method	Requirement	Result
Alreflex 1L1	BS EN ISO 10456 : 2007	Value achieved	150 MN·s·g <sup>-1</sup>
Alreflex 1L1 Super 'R' Class 0			

### 4 Safety and accessibility in use

Not applicable.

### 5 Protection against noise

Not applicable.

## 6 Energy economy and heat retention

Data were assessed for the following characteristics.

### 6.1 Thermal conductivity

The products were tested for thermal resistance and the results are given in Table 3.

*Table 3 Thermal resistance*

Product assessed	Assessment method	Requirement	Result
Alreflex 1L1	BS EN 12667 : 2001	Declared value	0.10 m <sup>2</sup> ·K·W <sup>-1</sup>
Alreflex 1L1 Super 'R' Class 0			0.10 m <sup>2</sup> ·K·W <sup>-1</sup>

### 6.2 Thermal performance

The products were tested for emissivity and the result is given in Table 4.

*Table 4 Outer surface emissivity*

Product assessed	Assessment method	Requirement	Result
Alreflex 1L1	BS EN ISO 22097 : 2023	Declared value	0.05
Alreflex 1L1 Super 'R' Class 0			

### 6.3 Conservation of fuel and power

6.3.1 The U value of a completed wall will depend on its structure and its internal finish. Example U values without additional insulation are given in Table 5.

*Table 5 Example U values<sup>(1)</sup> – partial fill insulation (50 mm residual cavity)*

Product	Aerated concrete block <sup>(2)</sup> $\lambda = 0.12$ (W·m <sup>-1</sup> ·K <sup>-1</sup> ) density = 400 kg·m <sup>-3</sup>	Medium concrete block <sup>(3)</sup> $\lambda = 0.32$ (W·m <sup>-1</sup> ·K <sup>-1</sup> ) density = 1300 kg·m <sup>-3</sup>	Dense concrete block <sup>(4)</sup> $\lambda = 1.13$ (W·m <sup>-1</sup> ·K <sup>-1</sup> ) density = 1800 kg·m <sup>-3</sup>
Alreflex 1L1/1L2 Super 'R' Class 0	0.52	0.72	0.85

(1) The U value calculations are based on the following:

- cavity wall ties – mild steel ( $\lambda = 50$  W·m<sup>-1</sup>·K<sup>-1</sup>), 2.5 per m<sup>2</sup>, 3.30 mm<sup>2</sup> cross-section
- 102.5 mm brick with conductivity 0.77 (W·m<sup>-1</sup>·K<sup>-1</sup>)
- 50 mm low emissivity cavity ( $R = 0.665$  m<sup>2</sup>·K·W<sup>-1</sup>) facing the inner surface of the external leaf.
- (2) 100 mm AAC block ( $\lambda = 0.12$  W·m<sup>-1</sup>·K<sup>-1</sup>) bridged by mortar (6.7%,  $\lambda = 0.88$  W·m<sup>-1</sup>·K<sup>-1</sup>) and 12.5 mm plasterboard ( $\lambda = 0.25$  W·m<sup>-1</sup>·K<sup>-1</sup>) affixed by plaster dabs (20%,  $\lambda = 0.43$  W·m<sup>-1</sup>·K<sup>-1</sup>) bridging a 15 mm air cavity ( $R = 0.17$  m<sup>2</sup>·K·W<sup>-1</sup>).
- (3) 100 mm medium block with conductivity 0.32 (W·m<sup>-1</sup>·K<sup>-1</sup>) bridged by mortar (6.7%,  $\lambda = 0.88$  W·m<sup>-1</sup>·K<sup>-1</sup>) and 13 mm dense plaster ( $\lambda = 0.57$  W·m<sup>-1</sup>·K<sup>-1</sup>).
- (4) 100 mm dense block with conductivity 1.13 (W·m<sup>-1</sup>·K<sup>-1</sup>) bridged by mortar (6.7%,  $\lambda = 0.88$  W·m<sup>-1</sup>·K<sup>-1</sup>) and 13 mm dense plaster ( $\lambda = 0.57$  W·m<sup>-1</sup>·K<sup>-1</sup>).

6.3.2 The products can contribute towards a construction satisfying the national Building Regulations in respect of energy economy and heat retention.

6.3.3 For improved energy or carbon savings, designers must consider appropriate compensating fabric/service measures.

## 7 Sustainable use of natural resources

Not applicable.

## 8 Durability

8.1 The potential mechanisms for degradation and the known performance characteristics of the materials in the products were assessed.

### 8.2 Service life

Under normal service conditions, the products will have a life equivalent to the building in which they are incorporated, provided they are designed, installed and maintained in accordance with this Certificate and the Certificate holder's instructions.

## PROCESS ASSESSMENT

Information provided by the Certificate holder was assessed for the following factors:

## 9 Design, installation, workmanship and maintenance

### 9.1 Design

9.1.1 The design process was assessed by the BBA, and the following requirements apply in order to satisfy the performance assessed in this Certificate.

9.1.2 External masonry cavity walls must be designed and constructed in accordance with the relevant recommendations of:

- BS 5250 : 2021
- BS 8000-3 : 2020
- BS EN 845-1 : 2013
- BS EN 1996-1-1 : 2005 and its UK National Annex
- BS EN 1996-1-2 : 2005 and its UK National Annex
- BS EN 1996-2 : 2006 and its UK National Annex
- BS EN 1996-3 : 2006 and its UK National Annex.

9.1.3 As with other forms of cavity wall insulation, where buildings need to comply with the *NHBC Standards*, specifiers must observe the requirements of that document.

9.1.4 Cavity wall ties with insulation-retaining fixings and, if required, any additional ties to BS EN 845-1 : 2013, must be used for structural stability in accordance with BS EN 1996-1-1 : 2005, BS EN 1996-2 : 2006 and BS EN 1996-3 : 2006, and their UK National Annexes.

9.1.5 Care must be taken in the overall design and construction of walls incorporating the products to ensure the provision of appropriate:

- cavity trays and DPCs
- cavity barriers
- resistance to the ingress of precipitation, moisture and dangerous gases from the ground
- resistance to sound transmission when flanking separating walls and floors.

9.1.6 Provided that external masonry cavity walls are designed and constructed to incorporate the precautions in this Certificate to prevent moisture penetration, the products will resist the transfer of precipitation to the inner leaf.

9.1.7 Window and door opening reveals must be constructed incorporating a cavity barrier/closer/DPC, as required.

9.1.8 The detailed provisions given in the documents supporting the national Building Regulations for when the products are installed in close proximity to certain flue pipes and/or heat-producing appliances must be followed.

9.1.9 Calculations of the thermal transmittance (U value) of a wall must be carried out in accordance with BS EN ISO 6946 : 2017 and BRE Report BR 443 : 2019.

9.1.10 Care must be taken in the overall design and construction of junctions with other elements and openings to minimise thermal bridges and air infiltration. Detailed guidance can be found in the documents supporting the national Building Regulations.

*Interstitial condensation*

9.1.11 Walls will adequately limit the risk of interstitial condensation when they are designed and constructed in accordance with BS 5250 : 2021.

9.1.12 If the products are to be used in the external wall of rooms expected to have high humidity, care must be taken to provide adequate permanent ventilation to avoid possible problems from the formation of interstitial condensation.

*Surface condensation*

9.1.13 In England and Wales, walls will adequately limit the risk of surface condensation when the thermal transmittance (U value) does not exceed  $0.7 \text{ W}\cdot\text{m}^{-2}\cdot\text{K}^{-1}$  at any point, and the junctions with other elements are designed in accordance with the guidance referred to in section 9.1.10 of this Certificate.

9.1.14 For buildings in Scotland, wall constructions will be acceptable when the thermal transmittance (U value) does not exceed  $1.2 \text{ W}\cdot\text{m}^{-2}\cdot\text{K}^{-1}$  at any point, and the junctions with other elements are designed in accordance with the guidance referred to in BS 5250 : 2021. Further guidance may be obtained from BRE Report BR 262 : 2002 and section 9.1.10 of this Certificate.

*Buildings up to and including 25 metres high (see also section 2 of this Certificate)*

9.1.15 The residual cavity width to be maintained during construction is 50 mm. This may reduce to 25 mm in isolated areas due to individual construction features [a minimum of 50 mm residual cavity width is required by the NHBC<sup>(1)</sup>]. This may be achieved by designing a cavity width which takes into account the dimensional tolerances of the components which make up the wall (by reference to the British Standards relating to the bricks, blocks and boards, or by using the data from the respective manufacturers). Allowances may need to be made for the quality of building operatives and the degree of site supervision or control available. The limitations in respect of exposure of the proposed building as set out in Table 6 of this Certificate must also be observed.

(1) The NHBC requirement for a residual cavity width is increased to 75 mm in areas of very severe exposure where the outer leaf is fairfaced masonry

*Table 6 Maximum allowable exposure index  $E^{(1)}$*

Construction	Maximum allowable exposure index $E^{(1)}$
All external masonry walls protected by: rendering (to BS EN 13914-1 : 2016), tile hanging, slate hanging, or timber, plastic or metal weatherboarding or cladding	No restriction
One or more external masonry walls constructed from facing clay brickwork or natural stone, the porosity of which exceeds 20% by volume. Mortar joints must be flush pointed or weatherstruck	100
One or more external masonry walls constructed from calcium silicate bricks, concrete blocks, reconstituted stone, or natural stone, the porosity of which is less than 20% by volume, or any material with raked mortar joints	88

(1) To BS 5618 : 1985.

9.1.16 From ground level, the maximum height of continuous cavity walls must not exceed 12 metres; above 12 metres, the maximum height of continuous cavity walls must not exceed 7 metres. In both cases, breaks must be in the form of continuous horizontal cavity trays and weepholes discharging to the outside.

9.1.17 An external render coat or other suitable finish must be applied in locations where such application would be normal practice; care must be taken to ensure that the residual cavity is not bridged by mortar.

*Buildings over 25 metres in height (see also section 2 of this Certificate)*

9.1.18 The width of the residual clear cavity to be achieved must be in excess of 50 mm, and the following additional requirements apply in addition to those stated in 9.1.15 to 9.1.17:

- the specifier must take extra care when detailing to ensure that the introduction of the insulation does not affect the weather resistance of the wall. Above average site supervision is recommended during installation of the products
- where, for structural reasons, the cavity width is reduced, eg by the intrusion of ring beams, a minimum residual cavity width of 25 mm must be maintained and extra care must be taken with fixings and weatherproofing, eg the inclusion of cavity trays with weepholes.

## 9.2 Installation

9.2.1 Installation instructions provided by the Certificate holder were assessed and judged to be appropriate and adequate.

9.2.2 Installation must be carried out in accordance with this Certificate and the Certificate holder's instructions. A summary of instructions and guidance is provided in Annex A if this Certificate.

9.2.3 It is essential that the spacing of wall ties/clips allows one long edge of each sheet to be secured at a minimum of two points.

9.2.4 Where protrusions occur in the cavity, the sheets must be carefully cut to fit.

9.2.5 If installation of the sheets is terminated below the highest level of the wall, the top edge of the insulation must be protected by a cavity tray and alternate perpendicular joints raked out to provide adequate drainage of water from the tray.

9.2.6 In all situations, it is particularly important to ensure during installation that:

- installation is carried out to the highest level on each wall, or the top edge of the insulation is protected by a cavity tray
- cavity trays are used with appropriate stop ends and weepholes at lintel level
- cavity battens and/or boards are used during construction to prevent bridging by mortar droppings
- wall ties are installed correctly and are thoroughly clean
- excess mortar is cleaned from the cavity face of the leading leaf and any debris removed from the cavity
- mortar droppings are cleaned from the exposed edges of installed products
- the DPC at ground level does not project into the cavity, as it can form a trap for mortar bridging
- raked or recessed mortar joints are avoided in very severe exposure areas.

## 9.3 Workmanship

Practicability of installation was assessed by the BBA, on the basis of Certificate holder's information. To achieve the performance described in this Certificate, installation of the products must be carried out by a competent general builder, or a contractor, experienced with these types of products.

## 9.4 Maintenance and repair

As the products are confined within the wall cavity and have suitable durability, maintenance is not required.

# 10 **Manufacture**

10.1 The production processes for the products have been assessed, and provide assurance that the quality controls are satisfactory according to the following factors:

10.1.1 The manufacturer has provided documented information on the materials, processes, testing and control factors.

10.1.2 The quality control operated over batches of incoming materials has been assessed and deemed appropriate and adequate.

10.1.3 The quality control procedures and product testing to be undertaken have been assessed and deemed appropriate and adequate.

10.1.4 The process for management of non-conformities has been assessed and deemed appropriate and adequate.

10.1.5 An audit of each production location was undertaken, and it was confirmed that the production process was in accordance with the documented process, and that equipment has been properly tested and calibrated.

† 10.2 The BBA has undertaken to review the above measures on a regular basis through a surveillance process, to verify that the specifications and quality control operated by the manufacturer are being maintained.

## **11 Delivery and site handling**

11.1 The Certificate holder stated that the products are delivered to site in rolls. Each roll is sealed with adhesive tape bearing the Certificate holder's name and the BBA logo incorporating the number of this Certificate. Within each wall tie box there is a leaflet giving basic installation instructions.

11.2 Delivery and site handling must be performed in accordance with the Certificate holder's instructions and this Certificate, including:

11.2.1 The products must be stored off the ground and under cover to protect them from precipitation, and in clean and dry conditions. Damaged products must be discarded.

Supporting information in this Annex is relevant to the products but has not formed part of the material assessed for the Certificate.

### Construction (Design and Management) Regulations 2015

### Construction (Design and Management) Regulations (Northern Ireland) 2016

Information in this Certificate may assist the client, designer (including Principal Designer) and contractor (including Principal Contractor) to address their obligations under these Regulations.

### Management Systems Certification for production

The management system of the manufacturer has been assessed and registered as meeting the requirements of BS EN ISO 9001 : 2015 and BS EN ISO 14001 : 2015 by Centre for Assessment (Certificates 23/1568 and 23/1570 respectively).

### Additional information on installation

A.1 The walls are constructed leading with either the inner or outer leaf. It is recommended that the inner leaf be constructed ahead of the outer leaf as this will ensure the laps are weathered to the outside (see Figure 1).

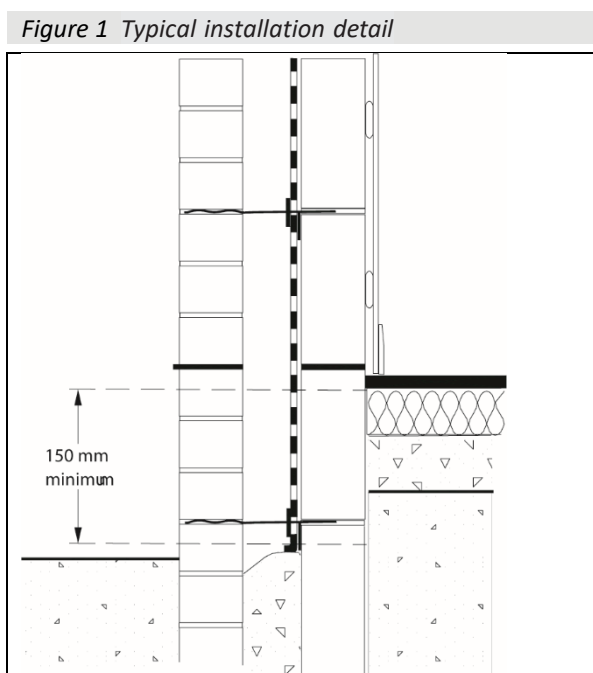

A.2 Walls are constructed in the conventional manner with the first run of wall ties as near as possible to, though not directly on, the DPC. A section of the inner leaf of the wall is built up using wall ties (see Figure 1) to a height of approximately 1.5 metre to accommodate an initial run of products of the appropriate width. For this initial run (lane), wall ties should be installed in the first, third, fourth and sixth block bed joint at 900 mm horizontal centres. The ties are installed with the triangular end embedded in the mortar and the down stand loop butted against the cavity face of the leaf. Any mortar extrusions must be removed before setting. The leaf should be left for a minimum of eight hours so that, when the products are pushed over the ties, sufficient strength has developed to prevent disturbance of the ties and damage to the walls.

Figure 2 Cavity wall tie and clip (all dimensions in mm)

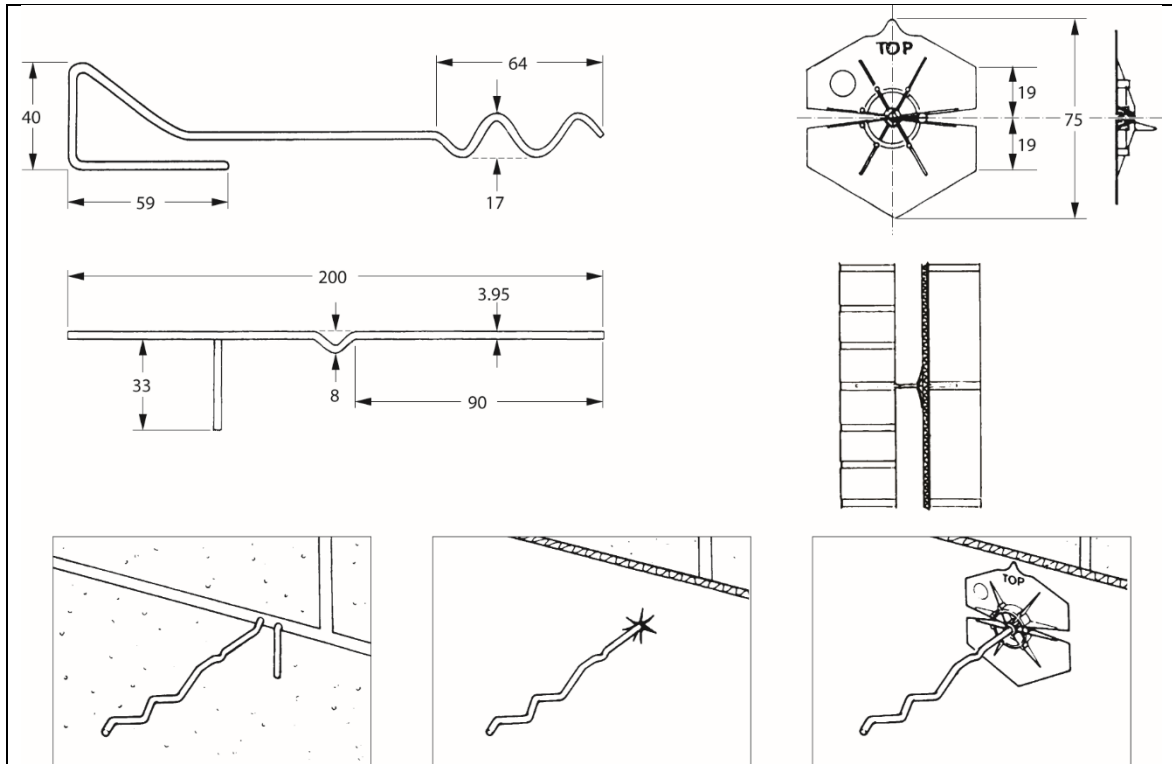

A.3 The time required to develop adequate strength will vary depending on several factors, such as type of masonry, mortar, or weather conditions.

A.4 When the first leaf has developed sufficient strength the products are fixed in a horizontal lane. The top edge of the foil should be aligned 75 mm above the top row of wall ties to create a weathered lap. The products should be fixed at one end and then stretched out along the wall and pushed over the wall ties.

A.5 It is preferable for two people to carry out this operation; one to maintain tension and the other to push the products over the ties.

A.6 The products are held in position against the loops in the wall ties by the plastic clips pushed onto the ties (see Figure 2).

A.7 After the initial run of the products has been installed, the second leaf is built up to one course below the uppermost row of wall ties leaving room for the installation of the following run. The first leaf is raised by approximately 1.2 metres to accommodate the next run of the products. The wall ties are installed at 450 mm vertical centres and 900 mm horizontal centres. The products are installed applying the same techniques as for the initial run. The construction sequence incorporating the appropriate widths of the products is repeated up to the required height.

A.8 An overlap of 150 mm must be incorporated between successive layers in the vertical plane, with the products installed in such a way that the lapped section is secured using wall ties and clips. The upper layer must lap over the lower layer when facing the outer leaf.

A.9 The lowest lane of foil may be allowed to protrude below DPC level to provide some edge insulation for the floor. Where two lanes abut, they must be fixed with an overlap of 150 mm and the ties pushed through the core of the overlap (see Figure 3).

Figure 3 Alreflex installed in cavity

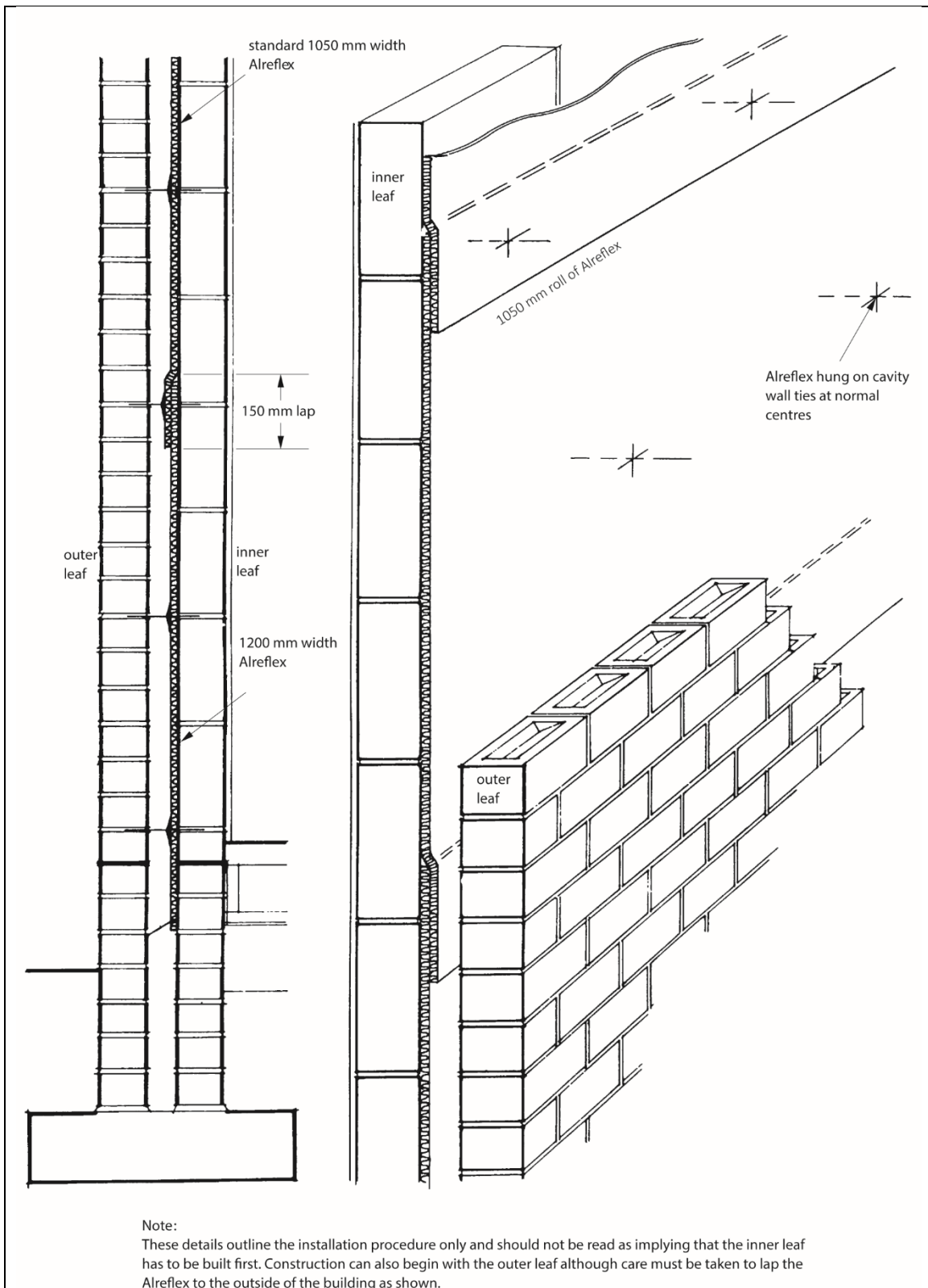

A.10 At external corners, the products are spaced away from the inner leaf by bedding the plastic clips, at regular intervals, into the mortar. At internal corners, special ties, formed by cutting 95 mm from the 'free' end of standard ties, are used to hold the products in position (see Figure 4).

A.11 The foil can be cut with a sharp knife or scissors to fit windows, doors and apertures. Where the foil meets a window or door frame it should be fixed to the jambs and cut off (see Figure 4). The products may be used to provide some insulation at joints (see section 9.1.9).

A.12 Care should be taken to avoid bringing the foil into contact with the inner leaf (see section A.8). Fixing at the tops of walls depends on the method used to seal the cavity; the material can be dressed under the cavity closer (see Figure 4) or, where appropriate, weathered to a cavity tray. Where vertical joints occur in the material, they should be formed on wall ties with a 150 mm vertical lap (see Figure 4).

Figure 4 Fixing details (dimensions in mm)

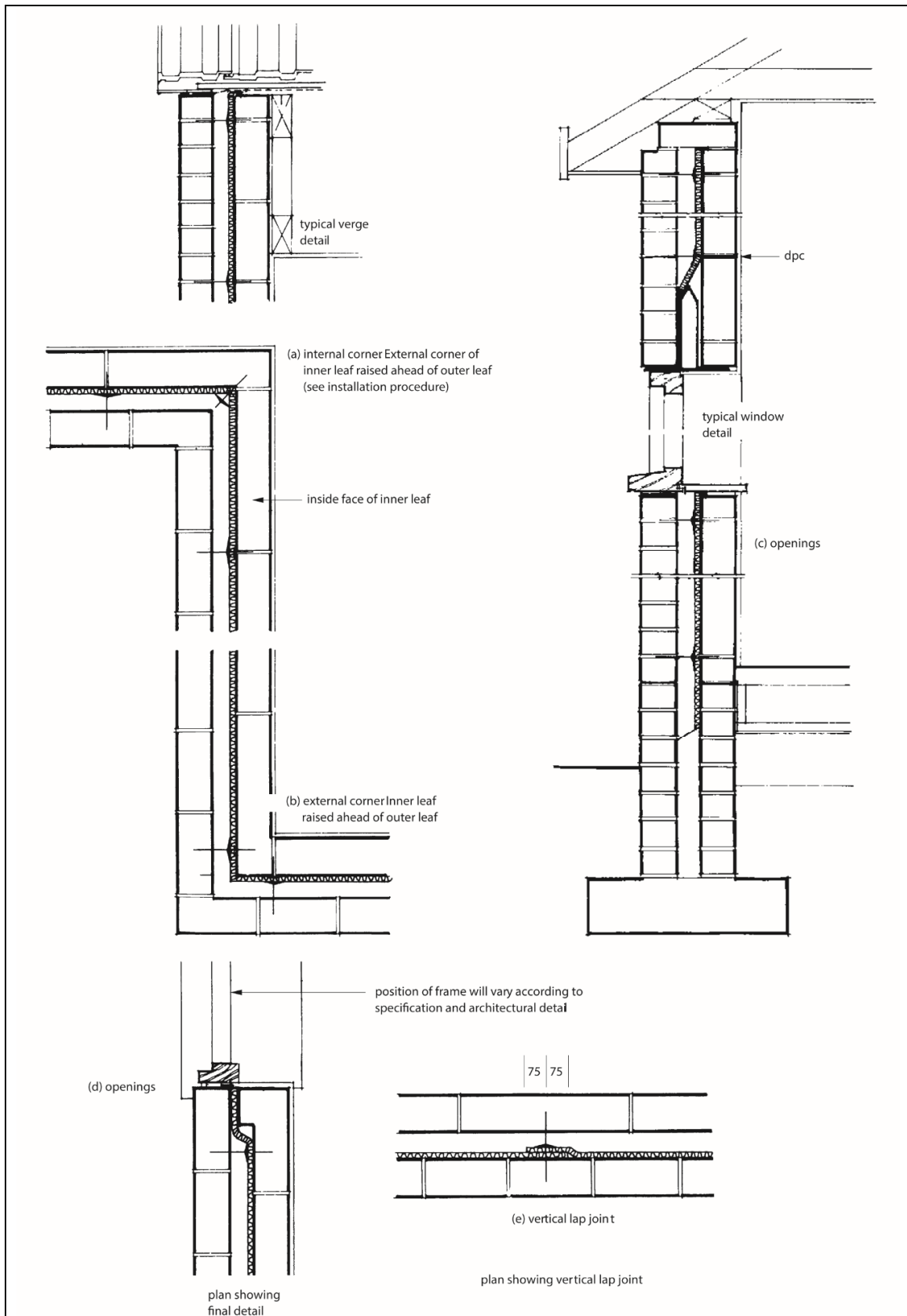

## Bibliography

- BRE Report BR 262 : 2002 *Thermal insulation: avoiding risks*
- BRE Report BR 443 : 2019 *Conventions for U-value calculations*
- BS 5250 : 2021 *Management of moisture in buildings — Code of practice*
- BS 5618 : 1985 *Code of practice for thermal insulation of cavity walls (with masonry or concrete inner and outer leaves) by filling with urea-formaldehyde (UF) foam systems*
- BS 8000-3 : 2020 *Workmanship on construction sites — Masonry — Code of practice*
- BS EN 845-1 : 2013 + A1 : 2016 *Specification for ancillary components for masonry — Wall ties, tension straps, hangers and brackets*
- BS EN 1996-1-1 : 2005 *Eurocode 6 : Design of masonry structures — General rules for reinforced and unreinforced masonry structures*
- NA to BS EN 1996-1-1 : 2005 *UK National Annex to Eurocode 6 : Design of masonry structures — General rules for reinforced and unreinforced masonry structures*
- BS EN 1996-1-2 : 2005 + A1 : 2012 *Eurocode 6 : Design of masonry structures — General rules — Structural fire design*
- NA to BS EN 1996-1-2 : 2005 + A1 : 2012 *UK National Annex to Eurocode 6 : Design of masonry structures — General rules — Structural fire design*
- BS EN 1996-2 : 2006 *Eurocode 6 : Design of masonry structures — Design considerations, selection of materials and execution of masonry*
- NA to BS EN 1996-2 : 2006 *UK National Annex to Eurocode 6 — Design of masonry structures — Design considerations, selection of materials and execution of masonry*
- BS EN 1996-3 : 2006 *Eurocode 6 : Design of masonry structures — Simplified calculation methods for unreinforced masonry structures*
- NA + A1 : 2014 to BS EN 1996-3 : 2006 *UK National Annex to Eurocode 6 — Design of masonry structures — Simplified calculation methods for unreinforced masonry structures*
- BS EN 12667 : 2001 *Thermal performance of building materials and products — Determination of thermal resistance by means of guarded hot plate and heat flow meter methods — Products of high and medium thermal resistance*
- BS EN 13501-1 : 2018 *Fire classification of construction products and building elements — Classification using data from reaction to fire tests*
- BS EN 13914-1 : 2016 *Design, preparation and application of external rendering and internal plastering — External rendering*
- BS EN ISO 6946 : 2017 *Building components and building elements — Thermal resistance and thermal transmittance — Calculation method*
- BS EN ISO 9001 : 2015 *Quality management systems — Requirements*
- BS EN ISO 10456 : 2007 *Building materials and products — Hygrothermal properties — Tabulated design values and procedures for determining declared and design thermal values*
- BS EN ISO 14001 : 2015 *Environmental Management systems — Requirements with guidance for use*
- BS EN ISO 22097 : 2023 *Thermal insulation for buildings — Reflective insulation products — Determination of thermal performance*

## Conditions of Certificate

### Conditions

1 This Certificate:

- relates only to the product that is named and described on the front page
- is issued only to the company, firm, organisation or person named on the front page – no other company, firm, organisation or person may hold or claim that this Certificate has been issued to them
- is valid only within the UK
- has to be read, considered and used as a whole document – it may be misleading and will be incomplete to be selective
- is copyright of the BBA
- and any matter arising out of or in connection with it or its subject matter (including non-contractual disputes or claims) is governed by and construed in accordance with the law of England and Wales.
- the courts of England and Wales shall have exclusive jurisdiction to settle any matter arising out of or in connection with this Certificate or its subject matter (including non-contractual disputes or claims).

2 Publications, documents, specifications, legislation, regulations, standards and the like referenced in this Certificate are those that were current and/or deemed relevant by the BBA at the date of issue or reissue of this Certificate.

3 This Certificate will be displayed on the BBA website, and the Certificate Holder is entitled to use the Certificate and Certificate logo, provided that the product and its manufacture and/or fabrication, including all related and relevant parts and processes thereof:

- are maintained at or above the levels which have been assessed and found to be satisfactory by the BBA
- continue to be checked as and when deemed appropriate by the BBA under arrangements that it will determine
- are reviewed by the BBA as and when it considers appropriate.

4 The BBA has used due skill, care and diligence in preparing this Certificate, but no warranty is provided.

5 In issuing this Certificate the BBA is not responsible and is excluded from any liability to any company, firm, organisation or person, for any matters arising directly or indirectly from:

- the presence or absence of any patent, intellectual property or similar rights subsisting in the product or any other product
- the right of the Certificate holder to manufacture, supply, install, maintain or market the product
- actual installations of the product, including their nature, design, methods, performance, workmanship and maintenance
- any works and constructions in which the product is installed, including their nature, design, methods, performance, workmanship and maintenance
- any loss or damage, including personal injury, howsoever caused by the product, including its manufacture, supply, installation, use, maintenance and removal
- any claims by the manufacturer relating to UKCA marking and CE marking.

6 Any information relating to the manufacture, supply, installation, use, maintenance and removal of this product which is contained or referred to in this Certificate is the minimum required to be met when the product is manufactured, supplied, installed, used, maintained and removed. It does not purport in any way to restate the requirements of the Health and Safety at Work etc. Act 1974, or of any other statutory, common law or other duty which may exist at the date of issue or reissue of this Certificate; nor is conformity with such information to be taken as satisfying the requirements of the 1974 Act or of any statutory, common law or other duty of care.

**British Board of Agrément**

1<sup>st</sup> Floor, Building 3, Hatters Lane  
Croxley Park, Watford  
Herts WD18 8YG

©2025

tel: 01923 665300  
clientservices@bbacerts.co.uk  
[www.bbacerts.co.uk](http://www.bbacerts.co.uk)